



Annual maintenance schedule and safety check

Pro-Care Beds - CB1 series

Nexus DMS Ltd
Unit 11, Lovett Road
Hampton Lovett Ind. Est.
Droitwich, Worcs, UK. WR9 0QG
Tel: 01905 774695 Fax: 01905 796081

www.nexusdms.co.uk
sales@nexusdms.co.uk

(For more detailed instructions on dis-assembly & re-assembly of the bed refer to the Pro-Care User Manual)

BED IN SITU:

1. Test all electrically powered functions for correct operation (11 on exploded view over page).
2. Check cable runs during & after operation to ensure that no fouling occurs & that cables are not trapped or over-extended.
3. Remove head & foot boards (14); siderails (20) (& lifting pole, if fitted)
4. On side furthest away from you remove disc knob (31) from captive carrier block mounting (3).
**** DISCONNECT THE MAINS 240 volt POWER CABLE FROM THE MAINS ELECTRICITY SOCKET ****

DIS-ASSEMBLY OF MATTRESS SUPPORT / SCISSOR LIFT UNITS:

5. Lifting bed away from you such that the scissor lift unit is facing you, place bed on its side.
6. Manually extend the backlift and leglift sections so that the mattress support unit is self-supporting.
7. Unscrew remaining disc knob (31) from the other captive carrier block mounting (3).
8. Carefully separate the scissor lift & mattress support units by pulling the captive carrier blocks at the foot end (3) away from their mounting cups & then sliding the carrier blocks at the head end (2) out of their slides. Wipe clean the inside of the slides & apply a little silicon grease.
9. Remove the locking strap (8.1) from the Main Controller (8) and remove the backlift and leglift actuator plugs,

MAINTENANCE OF MATTRESS SUPPORT UNIT:

10. Using the appropriate sized spanners &/or allen keys check that the nut/bolt/screw fixings at the 6 pivot points on the backlift and leglift sections are still securely fastened, but with sufficient 'slack' to allow the sections to hinge freely. Spray a little silicon grease on to the pivot points (wipe off any surplus).
11. Check the two wing screws or grub screws where the two halves of the mattress support unit join together for tightness.
12. Check the two mountings on each of the backlift & leglift actuators for security.
13. Check that there is no damage to the plugs & along the full length of each actuator cable.

MAINTENANCE OF SCISSOR LIFT UNIT:

14. Using the appropriate sized spanners &/or allen keys check that the nut/bolt/screw fixings at all the pivot points are still securely fastened, but with sufficient 'slack' to allow the sections to hinge / swivel freely. Spray a little silicon grease on to these swivel points (wipe off any surplus).
15. Check that the socket head screw mountings of the 4 carrier blocks (2 & 3) are securely fastened whilst allowing the blocks to swivel freely. Spray a little silicon grease on to these swivel points (wipe off any surplus).
16. Check the two mounting points on the bed lift actuator for security.
17. Check that there is no damage to the plug & along the full length of the actuator cable.
18. Check the mountings of the main controller (8) for security.
19. Check that the mains cable is securely seated & locked into its socket on the main controller & that there is no damage anywhere along its length. Check integrity of safety connector (13) & 2-pin plug.
20. Check that the 4 castors are still mounted securely in the 'legs' of the scissor lift unit & that the brake on each functions correctly.
21. Wipe clean the 2 slides adjacent to the main controller & apply a little silicon grease.

RE-ASSEMBLY OF BED:

22. Re-fit the mattress support unit to the scissor lift unit (a reversal of 5-9 above).
23. Re-fit head / foot boards & siderails - tighten wingscrews (30) securely. (Re-fit lifting pole if used)
24. Spray a little silicon grease into the 4 alloy slider channels & release button mechanisms and check for proper operation of the siderail 'lift & lock' function. (Wipe off any surplus grease).
25. Complete & attach label to bed to record date of annual safety check & initials of engineer responsible. (See over for typical example)



Annual maintenance schedule and safety check

Pro-Care Beds - CB1 series

Nexus DMS Ltd
Unit 11, Lovett Road
Hampton Lovett Ind. Est.
Droitwich, Worcs, UK. WR9 0QG
Tel: 01905 774695 Fax: 01905 796081

www.nexusdms.co.uk
sales@nexusdms.co.uk

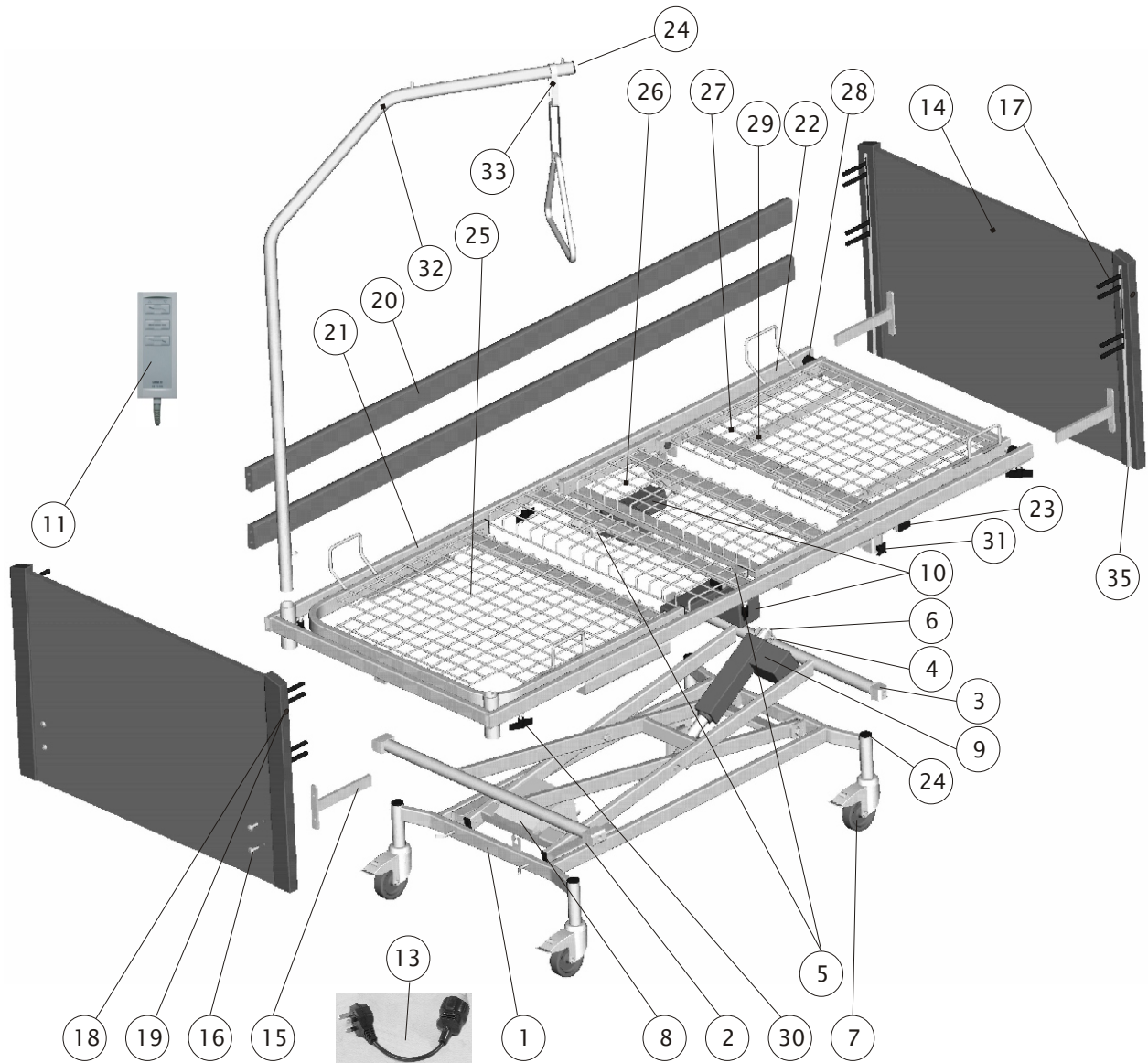

Typical type of label used to record date of annual Maintenance/Safety check



Annual Maintenance / Safety Check completed

Date: _____

By: _____

IMPORTANT NOTE - electrical appliance testing
Nexus electrically powered beds should be PAT2 tested annually (Portable Appliance Test).
It is the responsibility of the bed owner to arrange such a test.